

# TECHNICAL DATA SHEET

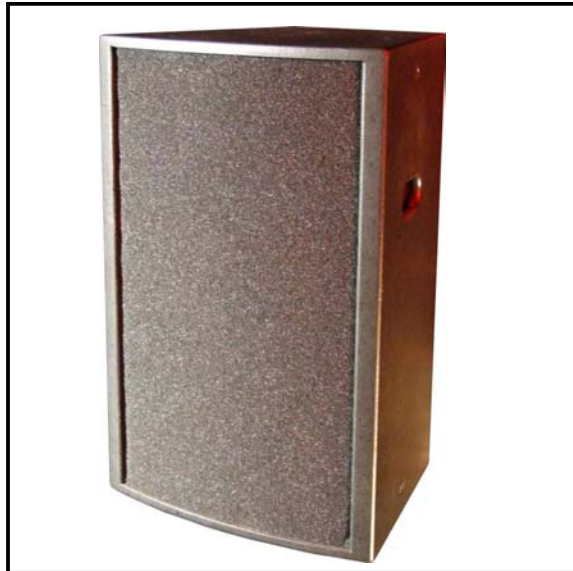

## EMS-121 LOUDSPEAKER



The EMS-121 is a compact, versatile loudspeaker, designed with flexibility in mind. The unrivalled ease-of-use afforded by passive loudspeaker technology allows the EMS-121 to be an extremely cost-effective and practical loudspeaker for a wide variety of applications, whilst providing a sonic performance that is unmatched by other loudspeakers of this type.

Typical applications for the EMS-121 include medium scale front of house for live use, theatrical front of house or effects loudspeakers, bar or club loudspeakers or reinforcement for corporate or A/V applications.

The compact enclosure is constructed from CNC-machined Birch plywood, and houses a reflex-loaded 12" (305mm) neodymium LF driver and a 1" (25mm) exit HF compression driver on a 60°H x 40°V waveguide (EMS-121) or a 90°H x 40°V waveguide (EMS-121w).

An internal UniPhase1 passive crossover maintains flat frequency and phase responses, allowing the EMS-121 to compare to products requiring dedicated control devices while only utilising one amplifier channel. The UniPhase network drastically reduces the time-smearing typically encountered with passive enclosures of this type.

### TECHNICAL SPECIFICATIONS

ENCLOSURE TYPE:	2-way reflex loaded
DIMENSIONS (HxWxD):	595 (23.4) x 402 (15.8) x 341 (13.4) mm/(ins)
NET/SHIPPING WEIGHT:	23/26kg
FREQUENCY RESPONSE <sup>1</sup> :	65Hz – 20KHz +/- 3dB
SENSITIVITY <sup>2</sup> :	98dB
DISPERSION <sup>3</sup> :	60°H x 40°V (EMS-121) 90°H x 40°V (EMS-121w)
DRIVE UNITS:	1 x 12" (305mm) neodymium LF cone drive unit 1 x 1" (25mm) exit HF compression drive unit
POWER HANDLING:	350W RMS, 700W program
MAXIMUM SPL:	126dB continuous, 132dB peak
NOMINAL IMPEDANCE:	8 ohms
CROSSOVER:	UniPhase1 internal passive
CONNECTORS:	2 x Neutrik Speakon™ NL4MPR
ENCLOSURE:	15mm (5/8") multi-laminate Birch plywood – rebated, screwed & glued. Finished in black Warnex textured paint
RIGGING/SUSPENSION:	12 x M10 internal flypoints 4 x M8 internal flypoints for Omnimount™ Series 60/Powerdrive™ Series 100 products 35mm polemount socket
GRILLE:	Black foam on polyester coated expanded steel mesh
OPTIONS:	EMS-121i (install only, vertical), EMS-121h (install only, horizontal) EMS-121 outdoor treatment EMS-121WP (weather protected outdoor model) Colours Connectors

### Notes on measurement conditions:

<sup>1</sup>Measured on-axis

<sup>2</sup>Average SPL over stated bandwidth with 1W input, measured at 1m

<sup>3</sup>Nominal dispersion, averaged over stated bandwidth

*EM Acoustics operates a continuous policy of research and development, and as such reserves the right to alter specifications without notice*

# TECHNICAL DATA SHEET



## EMS-121 LOUDSPEAKER

### ENGINEERING DRAWING

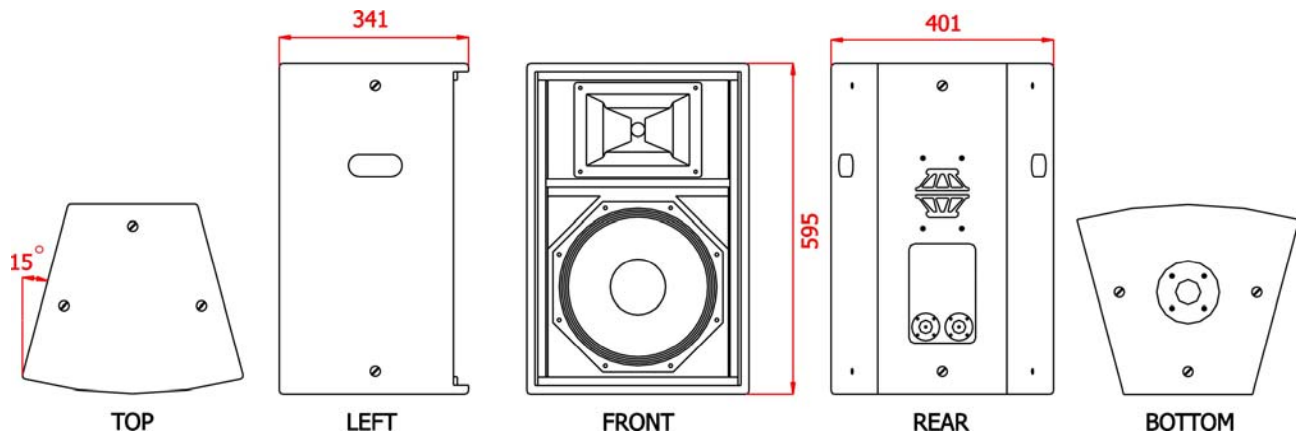

### OPTIONAL RIGGING HARDWARE



FC-121v FLYING CRADLE



FC-121h FLYING CRADLE



M10 FORGED  
SHOULDER EYEBOLTS



DFB-121 DUAL FLYBAR



POWERDRIVE WHH100  
WALL BRACKET

### ENCLOSURE OPTIONS

#### EMS-121i/EMS-121h

Dedicated installation versions of the EMS-121 without polemount or handle, and supplied with 1 x Neutrik Speakon™ NL4MP and 1 x 4-way barrier strip input (EMS-121i). The EMS-121h is supplied in a horizontal format, with either connector option.

#### EMS-121 outdoor treatment

Semi-outdoor version of EMS-121, designed for temporary outdoor use. Enclosure is supplied in standard configuration, with stainless steel fixings throughout and weatherproof coatings sprayed onto LF drive unit and woodwork before paint finish is applied.

#### EMS-121WP

Dedicated outdoor version of the EMS-121, designed for permanent installation. Supplied with no handles, rear logo, rear M8 points or polemount, with connector panel on underside to prevent moisture ingress. Stainless steel fixings throughout, and weatherproof coatings sprayed onto LF drive unit and onto woodwork before paint finish is applied.

#### Colours

Supplied as standard in black, however white & grey are available as options. By special order, any colour can be provided if the relevant RAL or Pantone colour code or a colour sample is provided.

#### Connectors

Neutrik Speakon™ NL4MP connectors supplied as standard. EMS-121 can be supplied with XLR connectors, or non-standard connectors by special order.