

i-12 SUBWOOFER



The i-12 is the largest subwoofer in the i-Series by EM Acoustics, and represents a unique approach to low frequency reproduction from a compact enclosure.

The i-12 was designed to provide an extreme low frequency solution for a variety of applications. The unique design provides unprecedented sonic depth from an enclosure of this size. With a response extending down to below 28Hz, the i-12 is ideal as true sub bass in live venues or nightclubs, or as an effect for theatres, museums, cinemas or even simulators.

The enclosure contains four high power 12" (305mm) drive units, loaded as two compound isobaric pairs. This design gives a useable response down to 27Hz, without any artificial equalisation. The i-12 can therefore add 'depth and warmth' to any system, even where larger subwoofers would normally have been used.

The rugged enclosure is constructed from CNC-machined Finnish multi-laminate Birch plywood, rebated, screwed & glued together for maximum strength. The enclosure is finished in black semi-matt textured paint, however other colours are available on request. Two perforated steel mesh grilles covered with acoustically transparent black foam protect the drive units from damage and moisture. For service purposes, the rear pair of drive units can be accessed via a removable door on the rear panel of the enclosure, and for touring purposes the WB-i12 wheelboard is available.

For added flexibility, the i-12 can be fitted with the optional DA-1 amplifier module, with the BP-i12 add-on backpack enclosure.

TECHNICAL SPECIFICATIONS

| | |
|-----------------------------------|---|
| ENCLOSURE TYPE: | compound isobaric subwoofer |
| DIMENSIONS (HxWxD): | 420 (16.5) x 823 (32.4) x 700 (27.6) mm/(ins) |
| NET/SHIPPING WEIGHT: | 83/86kg |
| FREQUENCY RESPONSE ¹ : | 27Hz – 100Hz +/- 3dB |
| SENSITIVITY ² : | 93dB |
| DISPERSION ³ : | Omnidirectional |
| DRIVE UNITS: | 4 x 12" (305mm) LF cone drive units |
| POWER HANDLING: | 1000W RMS, 2000W program |
| MAXIMUM SPL: | 126dB continuous, 132dB peak |
| NOMINAL IMPEDANCE: | 2 ohms |
| CROSSOVER: | Active, recommended below 100Hz (24dB/Octave L-R) |
| CONNECTORS: | 2 x Neutrik Speakon™ NL4MP |
| ENCLOSURE: | 18mm (3/4") multi-laminate Birch plywood – rebated, screwed & glued. Finished in black Warnex textured paint |
| GRILLE: | Acoustically transparent black foam on polyester coated perforated steel mesh |
| OPTIONS: | Colours Connectors DA-1 Amplifier Module |

Notes on measurement conditions:

¹Measured on-axis

²Average SPL over stated bandwidth with 1W input, measured at 1m

³Nominal dispersion, averaged over stated bandwidth

EM Acoustics operates a continuous policy of research and development, and as such reserves the right to alter specifications without notice

TECHNICAL DATA SHEET



i-12 SUBWOOFER

ENGINEERING DRAWING

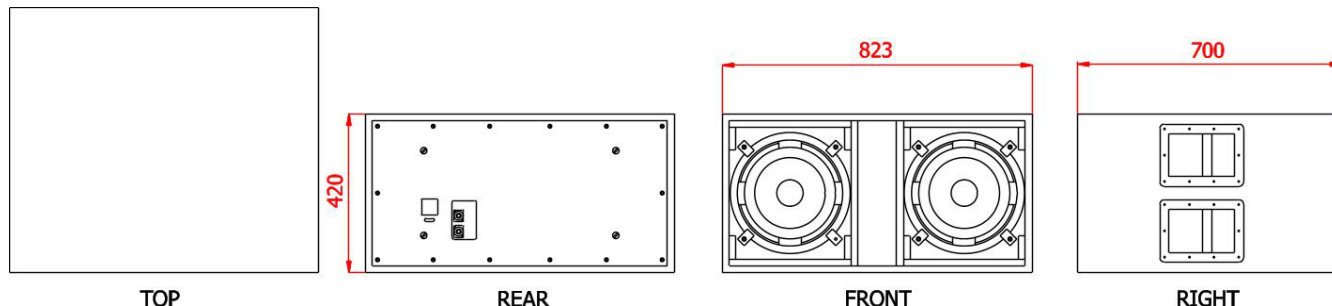

SYSTEM CONFIGURATION OPTIONS

The following shows possible system uses of the i-12

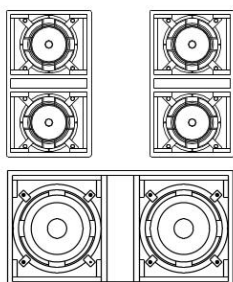
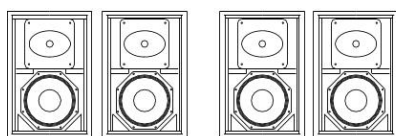

4 x EMS-81
2 x i-8
1 x i-12
DISTRIBUTED SOUND SYSTEM

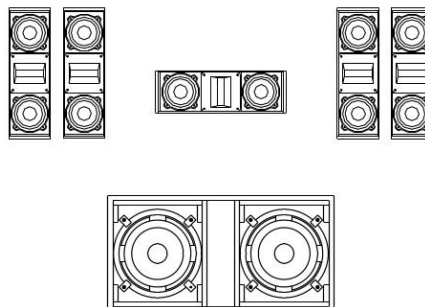

5 x i-2
1 x i-12
5.1 SURROUND SOUND SYSTEM

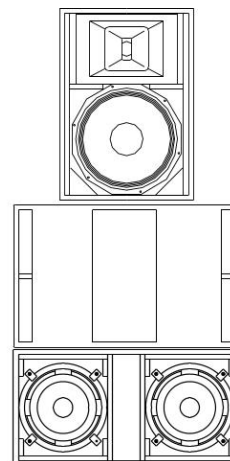

2 x EMS-152
1 x EMS-215
1 x i-12
FOH SOUND SYSTEM

ENCLOSURE OPTIONS

Colours

Supplied as standard in black, however white & grey are available as options. By special order, any colour can be provided if the relevant RAL or Pantone colour code or a colour sample is provided.

Connectors

Neutrik Speakon™ NL4MP connectors supplied as standard. i-12 can be supplied with XLR connectors, or non-standard connectors by special order.

